

■ Description

The HWA1441 is a high-efficiency, wide instantaneous bandwidth, fully input/output matched power amplifier (PA) with high gain and linearity.

The compact 16-pin 5 × 5 mm PA is designed for TDD system, support 5G NR FR1 band n79 Wireless Infrastructure operating from 4400 to 5000MHz.

The active biasing circuitry is integrated to compensate PA performance over temperature, voltage, and process variation.

This amplifier is part of Hexawave's high-efficiency 4W PA RF product line designed for wireless infrastructure supporting major 3GPP bands.

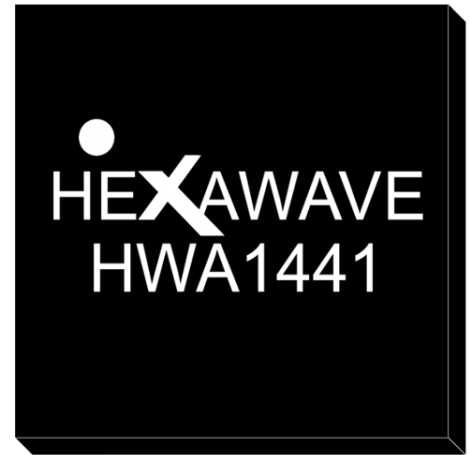

■ Features

- **Wide instantaneous signal bandwidth** : 100 MHz
- **High Efficiency** : PAE = 31.0% @ Pout = 28 dBm
- **High Linearity** : ACLR < -50 dBc @ Pout = 28 dBm with DPD (5G NR, 8.5 dB PAR CCDF 0.01% signal)
- **High output power** : Psat > 35 dBm
- **High power gain** : 35.5 dB
- **Single supply voltage** : Vcc = 5.0 V
- **Integrated enable On/Off function**: PAEN = 2.0 V
- **Integrated active bias** : performance compensated over temp
- **50 Ω matched input and output**
- **Compact (16-pin, 5 × 5 × 1.07 mm) package (MSL3, 260 °C per JEDEC J-STD-020)**

■ Functional Block Diagram

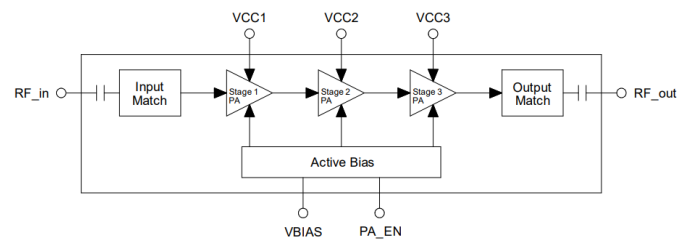

■ Applications

- **Supports 5G TDD systems**
- **Supports 3GPP 5G NR FR1 bands n79**
- **Small cells for wireless communications infrastructure and massive MIMO**
- **Repeaters / DAS**
- **General purpose wireless**

■ Absolute Maximum Ratings

Parameter	Symbol	Min	Max	Units
RF Input Power (CW)	P _{IN}		+10	dBm
Supply Voltage (VCC1, 2, 3 and VBIAS)	V _{CC}		5.5	V
PA Enable	V _{EN}		3.6	V
Operating Temperature	T _{op}	-40	+110	°C
Storage Temperature	T _{STG}	-55	+125	°C
Junction Temperature (for 10 ⁶ hours MTTF)	T _J		+175	°C
Power Dissipation	P _D		1.83	W
Device Thermal Resistance	θ _{JC}		15	°C/W
Electrostatic Discharge :	ESD			
Charged Device Model (CDM)			500	V
Human Body Model (HBM)			1000	V

Note : If the satisfied of any one or more of the above conditions will lead to equipment damage.

ESD HANDLING: Although this device is designed to be as robust as possible, electrostatic discharge (ESD) can damage this device. This device must be protected at all times from ESD when handling or transporting. Static charges may easily produce potentials of several kilovolts on the human body or equipment, which can discharge without detection. Industry-standard ESD handling precautions should be used at all times.

■ Recommended Operating Ranges

Parameter	Symbol	Min	Typ	Max	Unit
Operation Frequency	Freq.	4.4		5.0	GHz
Supply Voltage (VCC1, 2, 3 and VBIAS)	V _{CC}	4.75	5.0	5.5	V
PA Enable ON OFF	V _{EN}	1.7	2.0 0	3.6 0.5	V
PA Enable Current*	I _{EN}		5	10	uA
Operation Temperature	T _C	-40	+25	+110	°C

*Note : This current is when PA Enable is 2V, if the voltage increases, the current will also increase accordingly.

■ Electrical Specifications

VCC1, 2, 3 = VBIAS = 5.0V, PA_EN = 2.0V, Tc = 25°C, Input/Output Impedance 50Ω, unless otherwise noted

• Small Signal Characteristics

Parameter	Symbol	Test Conditions	Min	Typ	Max	Unit
Frequency	Freq.		4400	4700	5000	MHz
Small Signal Gain	S21	P _{IN} = -30dBm	32.6	35.0		dB
Input Return Loss	S11	P _{IN} = -30dBm		13.5	24.3	dB
Output Return Loss	S22	P _{IN} = -30dBm		11.7	30	dB
Reverse Isolation	S12	P _{IN} = -30dBm		50.8		dB
Quiescent Current	I _{cq}	No RF Signal		109		mA

• Large Signal Characteristics

Parameter	Symbol	Test Conditions	Min	Typ	Max	Unit
Frequency	Freq.			4400		MHz
Gain @+28dBm	S21	P _{out} = +28dBm		36.1		dB
ACLR @+28dBm	ACLR	100MHz 5G NR 8.5dB PAR Signal P _{out} = +28dBm		-31.5		dBc
Output Power for 1 dB Compression	OP1dB	CW, Reference to Gain @ P _{out} = 20dBm		29.1		dBm
Saturated Output Power	P _{SAT}	Use duty cycle 100% CW tone		33.3		dBm
2nd Harmonic	2f ₀	CW, P _{out} = +28dBm		-30.5		dBc
3rd Harmonic	3f ₀	CW, P _{out} = +28dBm		-41.3		dBc
Power Added Efficiency	PAE	CW, P _{out} = +28dBm		17.1		%
Total Operating Current	I _{total}	pins 5, 12, 14 and 16 P _{out} = +28dBm		751		mA
RF turn-on / turn-off time				200		ns

Parameter	Symbol	Test Conditions	Min	Typ	Max	Unit
Frequency	Freq.			4500		MHz
Gain @+28dBm	S21	P _{OUT} = +28dBm		35.9		dB
ACLR @+28dBm	ACLR	P _{OUT} = +28dBm (100MHz 5G NR, 8.5dB PAR Signal)		-32.0		dBc
Output Power for 1 dB Compression	OP1dB	CW, Reference to Gain (P _{out} = 20dBm)		31.8		dBm
Saturated Output Power	P _{SAT}	Use duty cycle100% CW tone		35.2		dBm
2nd Harmonic	2f ₀	CW, P _{OUT} = +28dBm		-35.7		dBc
3rd Harmonic	3f ₀	CW, P _{OUT} = +28dBm		-44.5		dBc
Power Added Efficiency	PAE	CW, P _{OUT} = +28dBm		22.2		%
Total Operating Current	I _{total}	Pin 5, 12, 14 and 16 P _{OUT} = +28dBm		562		mA
RF turn-on / turn-off time				200		ns

Parameter	Symbol	Test Conditions	Min	Typ	Max	Unit
Frequency	Freq.			4600		MHz
Gain @+28dBm	S21	P _{OUT} = +28dBm		35.5		dB
ACLR @+28dBm	ACLR	P _{OUT} = +28dBm (100MHz 5G NR, 8.5dB PAR Signal)		-32.5		dBc
Output Power for 1 dB Compression	OP1dB	CW, Reference to Gain (P _{out} = 20dBm)		33.2		dBm
Saturated Output Power	P _{SAT}	Use duty cycle100% CW tone		36.1		dBm
2nd Harmonic	2f ₀	CW, P _{OUT} = +28dBm		-41.1		dBc
3rd Harmonic	3f ₀	CW, P _{OUT} = +28dBm		-46.6		dBc
Power Added Efficiency	PAE	CW, P _{OUT} = +28dBm		28.0		%
Total Operating Current	I _{total}	Pin 5, 12, 14 and 16 P _{OUT} = +28dBm		457		mA
RF turn-on / turn-off time				200		ns

Parameter	Symbol	Test Conditions	Min	Typ	Max	Unit
Frequency	Freq.			4700		MHz
Gain @+28dBm	S21	P _{OUT} = +28dBm		35.5		dB
ACLR @+28dBm	ACLR	P _{OUT} = +28dBm (100MHz 5G NR, 8.5dB PAR Signal)		-33.4		dBc
Output Power for 1 dB Compression	OP1dB	CW, Reference to Gain (P _{out} = 20dBm)		33.6		dBm
Saturated Output Power	P _{SAT}	Use duty cycle100% CW tone		36.1		dBm
2nd Harmonic	2f ₀	CW, P _{OUT} = +28dBm		-46.7		dBc
3rd Harmonic	3f ₀	CW, P _{OUT} = +28dBm		-49.8		dBc
Power Added Efficiency	PAE	CW, P _{OUT} = +28dBm		31.0		%
Total Operating Current	I _{total}	Pin 5, 12, 14 and 16 P _{OUT} = +28dBm		417		mA
RF turn-on / turn-off time				200		ns

Parameter	Symbol	Test Conditions	Min	Typ	Max	Unit
Frequency	Freq.			4800		MHz
Gain @+28dBm	S21	P _{OUT} = +28dBm		35.9		dB
ACLR @+28dBm	ACLR	P _{OUT} = +28dBm (100MHz 5G NR, 8.5dB PAR Signal)		-33.5		dBc
Output Power for 1 dB Compression	OP1dB	CW, Reference to Gain (P _{out} = 20dBm)		33.6		dBm
Saturated Output Power	P _{SAT}	Use duty cycle100% CW tone		35.9		dBm
2nd Harmonic	2f ₀	CW, P _{OUT} = +28dBm		-50.6		dBc
3rd Harmonic	3f ₀	CW, P _{OUT} = +28dBm		-51.1		dBc
Power Added Efficiency	PAE	CW, P _{OUT} = +28dBm		29.7		%
Total Operating Current	I _{total}	Pin 5, 12, 14 and 16 P _{OUT} = +28dBm		437		mA
RF turn-on / turn-off time				200		ns

Parameter	Symbol	Test Conditions	Min	Typ	Max	Unit
Frequency	Freq.			4900		MHz
Gain @+28dBm	S21	P _{OUT} = +28dBm		35.8		dB
ACLR @+28dBm	ACLR	P _{OUT} = +28dBm (100MHz 5G NR, 8.5dB PAR Signal)		-31.2		dBc
Output Power for 1 dB Compression	OP1dB	CW, Reference to Gain (P _{out} = 20dBm)		33.5		dBm
Saturated Output Power	P _{SAT}	Use duty cycle100% CW tone		35.5		dBm
2nd Harmonic	2f ₀	CW, P _{OUT} = +28dBm		-54.1		dBc
3rd Harmonic	3f ₀	CW, P _{OUT} = +28dBm		-53.6		dBc
Power Added Efficiency	PAE	CW, P _{OUT} = +28dBm		25.6		%
Total Operating Current	I _{total}	Pin 5, 12, 14 and 16 P _{OUT} = +28dBm		500		mA
RF turn-on / turn-off time				200		ns

Parameter	Symbol	Test Conditions	Min	Typ	Max	Unit
Frequency	Freq.			5000		MHz
Gain @+28dBm	S21	P _{OUT} = +28dBm		34.7		dB
ACLR @+28dBm	ACLR	P _{OUT} = +28dBm (100MHz 5G NR, 8.5dB PAR Signal)		-29.3		dBc
Output Power for 1 dB Compression	OP1dB	CW, Reference to Gain (P _{out} = 20dBm)		33.2		dBm
Saturated Output Power	P _{SAT}	Use duty cycle100% CW tone		34.9		dBm
2nd Harmonic	2f ₀	CW, P _{OUT} = +28dBm		-52.9		dBc
3rd Harmonic	3f ₀	CW, P _{OUT} = +28dBm		-53.5		dBc
Power Added Efficiency	PAE	CW, P _{OUT} = +28dBm		22.0		%
Total Operating Current	I _{total}	Pin 5, 12, 14 and 16 P _{OUT} = +28dBm		574		mA
RF turn-on / turn-off time				200		ns

Notes :

- 1. Performance is guaranteed only under the conditions listed in this table.*
- 2. RF turn-on time is measured from the time the PA enable reaches 50% of PA enable "on" level to the time at which the RF output power achieves 90% of the average steady-state "on" level.*
- 3. RF turn-off time is measured from the time the PA enable reaches 50% of PA enable "on" level to the time at which the RF output power decreases to 10% of the average steady-state "on" level.*

Typical Performance Characteristics

VCC1, 2, 3 = VBIAS = 5.0V, PA_EN = 2.0V, Freq. = 4900MHz, TC = 25°C, Input/Output Impedance = 50Ω, unless otherwise noted

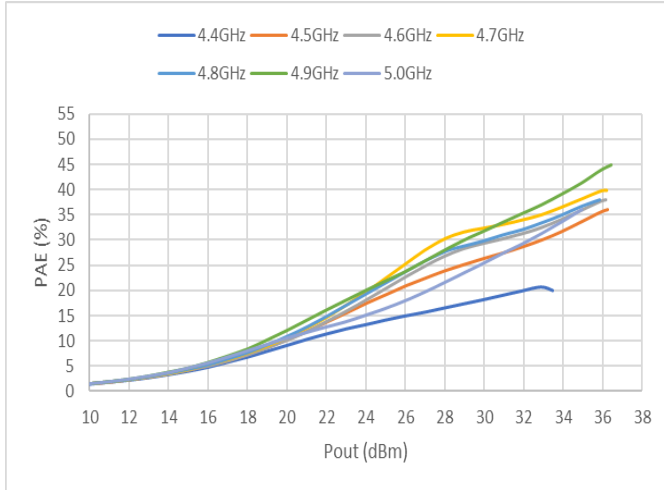

Figure 1. PAE vs Pout (CW) Across Frequency

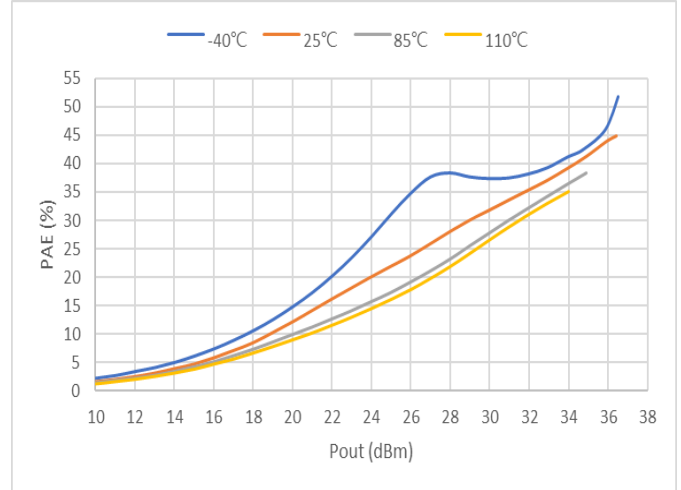

Figure 2. PAE vs Pout (CW) Across Temperature

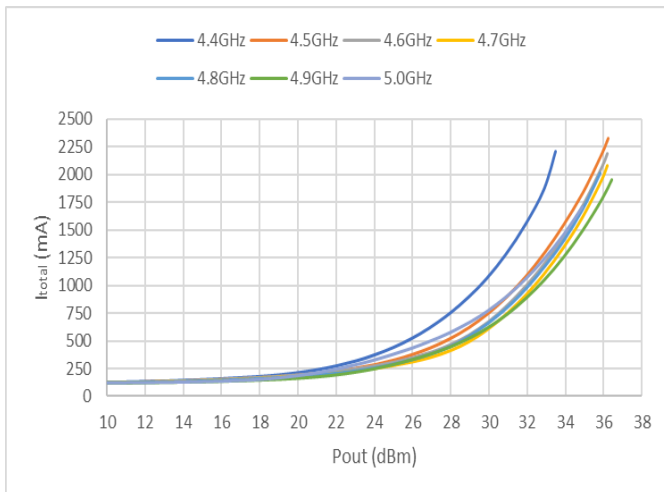

Figure 3. I_{total} vs Pout Across Frequency

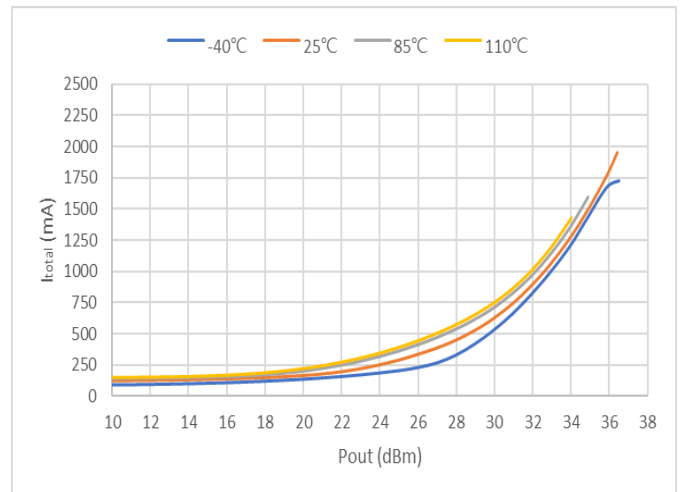

Figure 4. I_{total} vs Pout Across Temperature

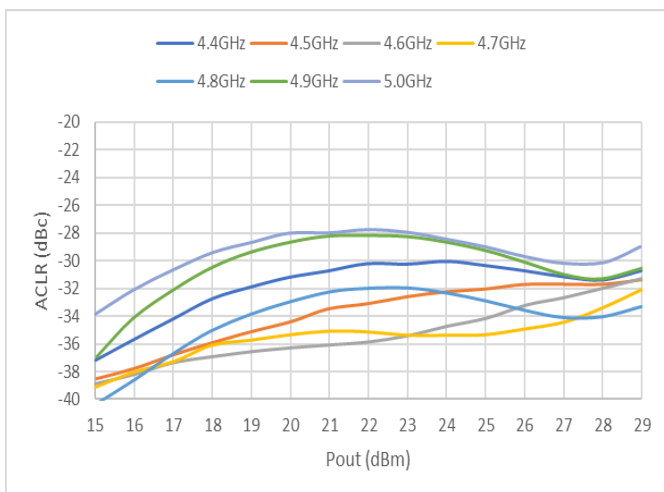

Figure 5. ACLR (1x100 MHz) vs Pout Across Frequency

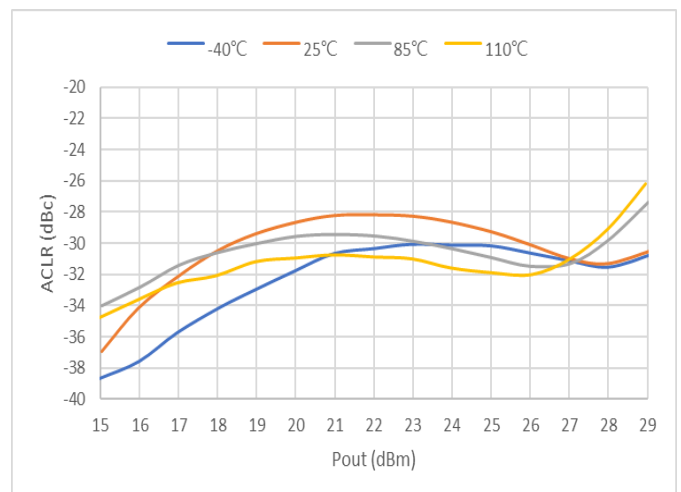

Figure 6. ACLR (1x100 MHz) vs Pout Across Temperature

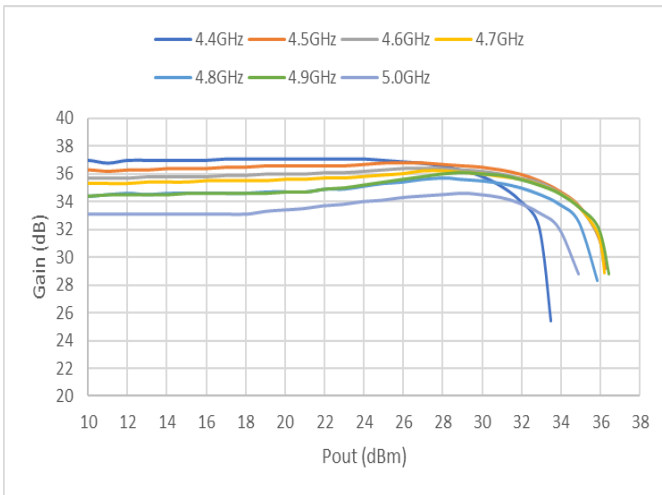

Figure 7. Gain vs Pout Across Frequency

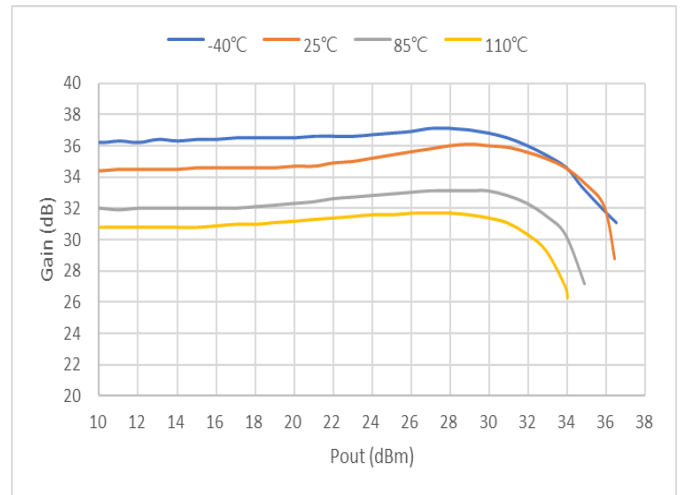

Figure 8. Gain vs Pout Across Temperature

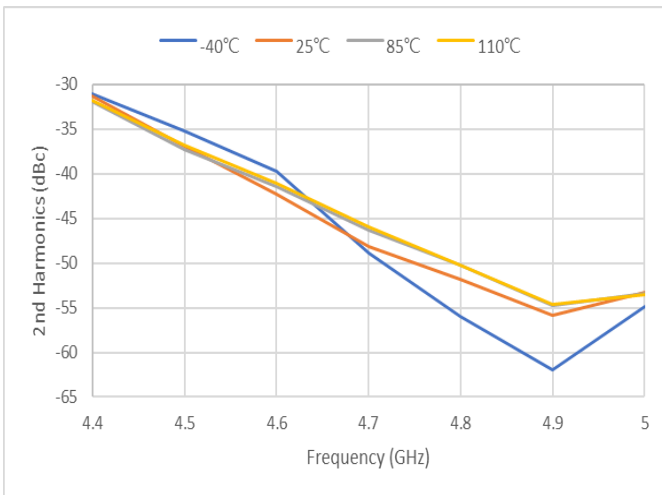

Figure 9. 2nd Harmonic @ +28 dBm (CW) vs Frequency Across Temperature

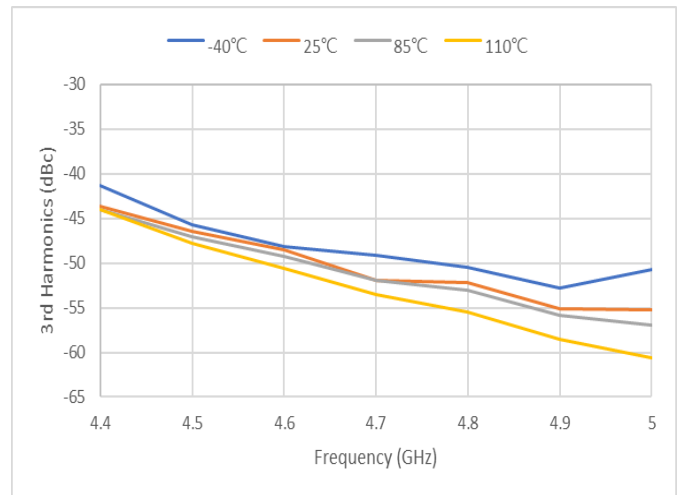

Figure 10. 3rd Harmonic @ +28 dBm (CW) vs Frequency Across Temperature

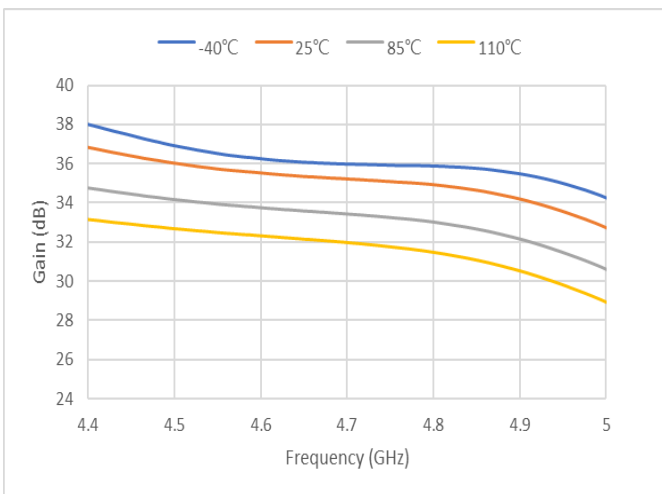

Figure 11. Small Signal Gain vs Frequency Across Temperature

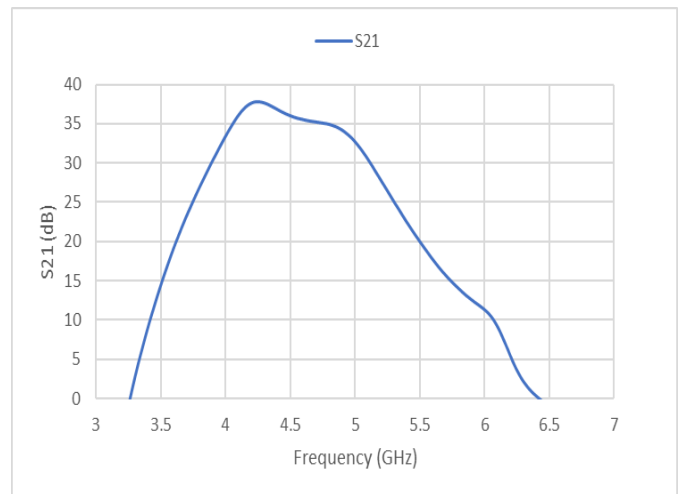

Figure 12. Wide-Band S21 vs Frequency

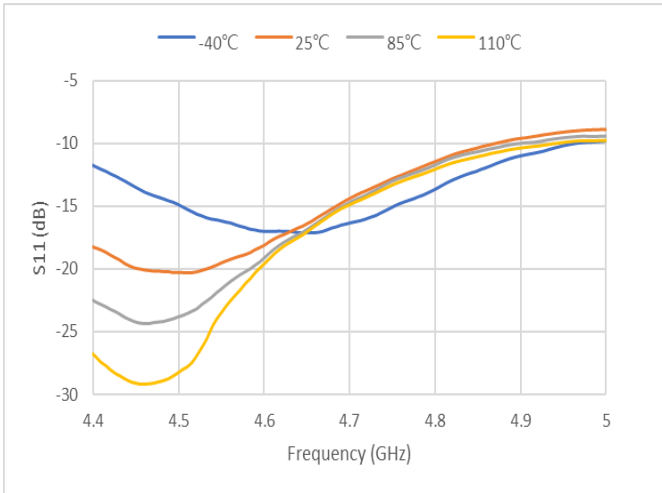

Figure 13. S11 vs Frequency Across Temperature (Pin = -30 dBm)

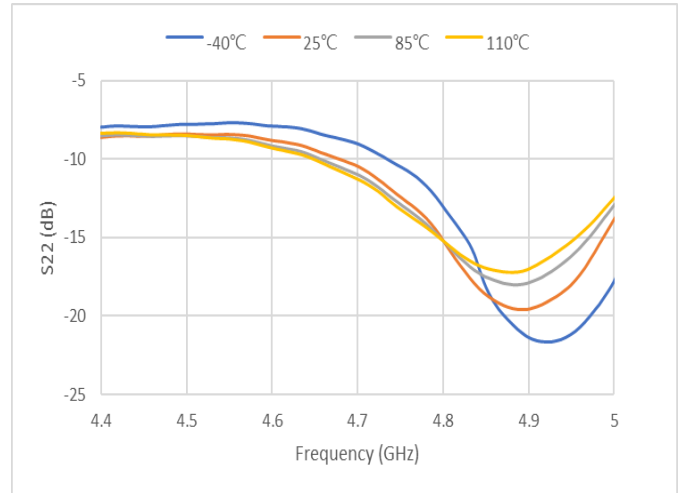
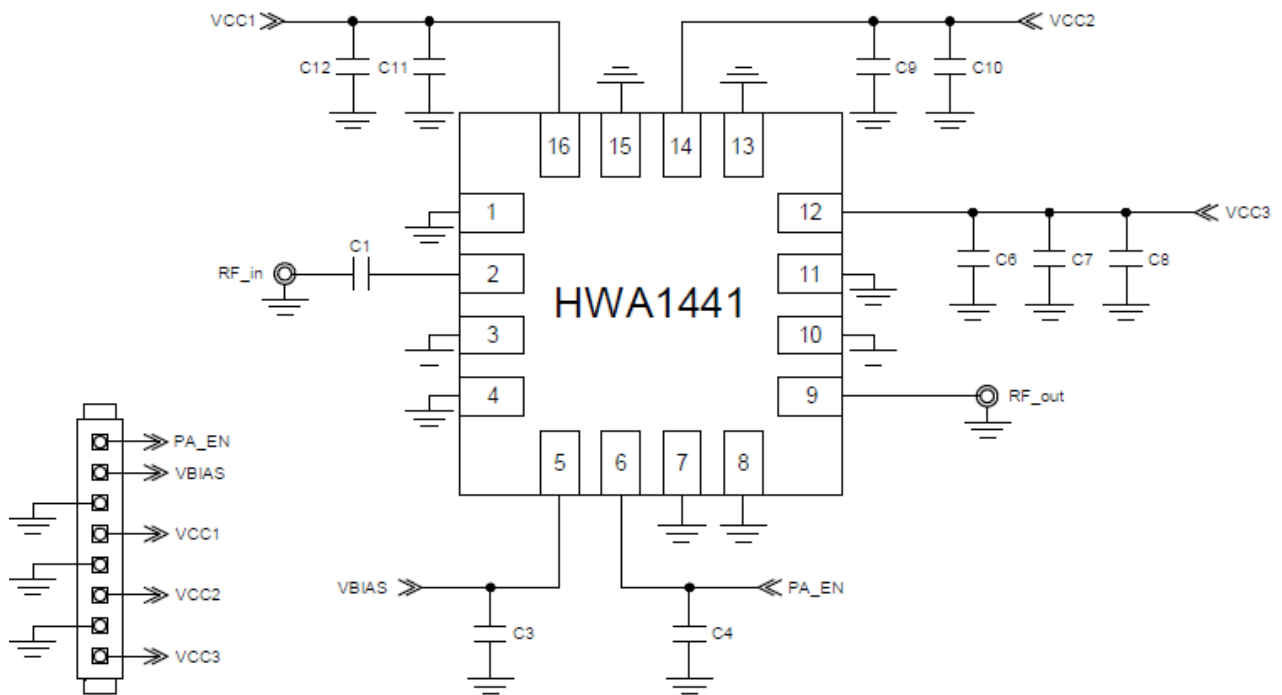

Figure 14. S22 vs Frequency Across Temperature (Pin = -30 dBm)

Application Circuit



Pin Assignments

Pin No.	Name	Description	Pin No.	Name	Description
1	GND	Ground	9	RF_out	RF Output Port
2	RF_in	RF Input Port	10	GND	Ground
3	GND	Ground	11	GND	Ground
4	GND	Ground	12	VCC3	Stage 3 Collector Voltage
5	VBIAS	Bias Voltage	13	GND	Ground
6	PA_EN	PA Enable	14	VCC2	Stage 2 Collector Voltage
7	GND	Ground	15	GND	Ground
8	GND	Ground	16	VCC1	Stage 1 Collector Voltage

Note :

The matching circuits are contained within the device. The HWA1441 is internally matched for maximum output power and efficiency. The input and output stages are independently supplied using the VCC1, VCC2, and VCC3 supply lines (pins 16, 14, and 12, respectively). The DC control voltage that sets the bias is supplied by the VBIAS signal (pin 5).

■ Evaluation Board Bill of Material (BOM)

<i>Component</i>	<i>Value / Part Number</i>	<i>Description</i>
IC	HWA1441	4.4G to 5.0GHz, High-Efficiency Power Amplifier
C1	0R	Resistor, 0402
C3	1uF	Ceramic Capacitor, 0402
C4, C7	3300pF	Ceramic Capacitor, 0402
C6	1uF	Ceramic Capacitor, 0402
C8, C10, C12	10uF	Ceramic Capacitor, 1206
C9	0.47uF	Ceramic Capacitor, 0402
C11	0.1uF	Ceramic Capacitor, 0402

Note : The center ground pad must have a low inductance and low thermal resistance connection to the application's printed circuit board ground plane.

■ Evaluation Board Test Procedure

- ✧ Turn-On Sequence
 1. Connect 50 Ohm Test Equipment or Load to the input and output RF ports of the Evaluation Board.
 2. Connect the DC ground.
 3. Connect all VCCs and VBIAS lines to a +5.0 V supply. Connect PA_EN to a 2.0 V supply.
 4. Without applying RF, turn on the 5.0 V supply, then turn on the 2.0 V PA_EN.
 5. Apply RF signal data at -30 dBm and observe that the gain of the device is correct. Begin measurements.
- ✧ Turn-Off Sequence
 1. Turn off the RF input to the device.
 2. Turn off PA_EN (set to 0 V).
 3. Turn off all VCCs and VBIAS.

Note : It is important to adjust the VCC voltage sources so that +5.0 V is measured at the board. High collector currents drop the collector voltage significantly if long leads are used. Adjust the bias voltage to compensate.

■ Evaluation Board Assembly Drawing

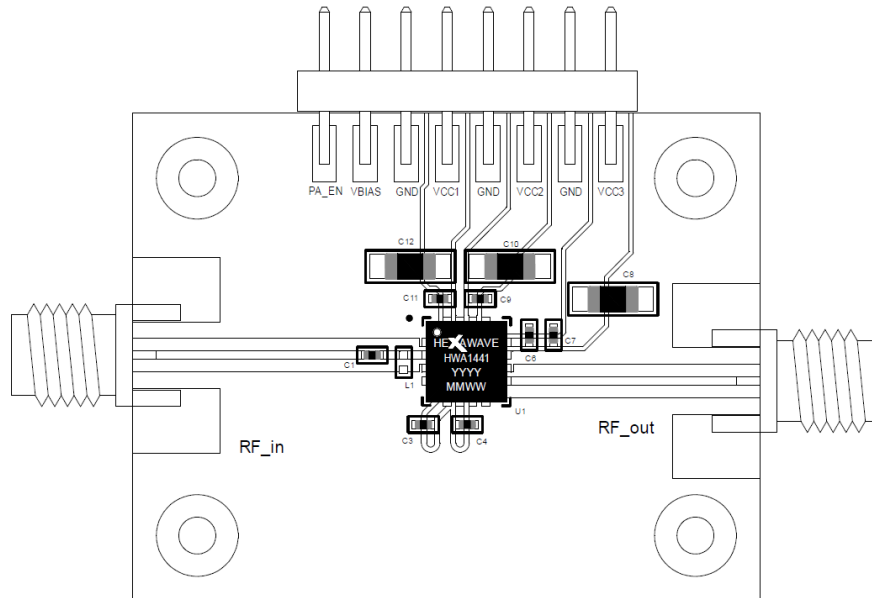

Notes :

1. The C1 component shown in this assembly is a 0Ω resistor.
2. The L1 component shown in this assembly is DNI.

■ Board Layer Detail

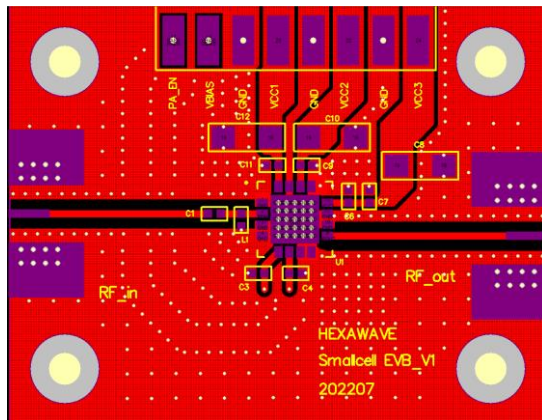

Layer 1 + Top Mask

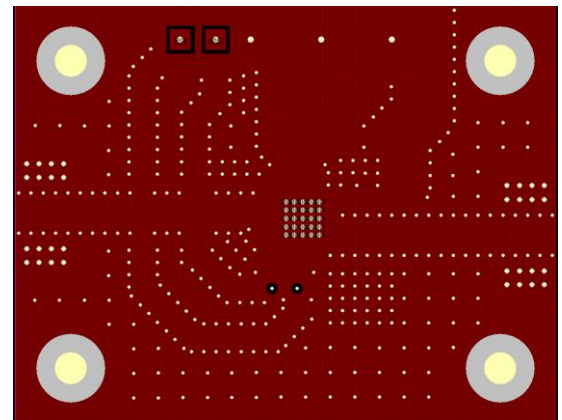

Layer 2

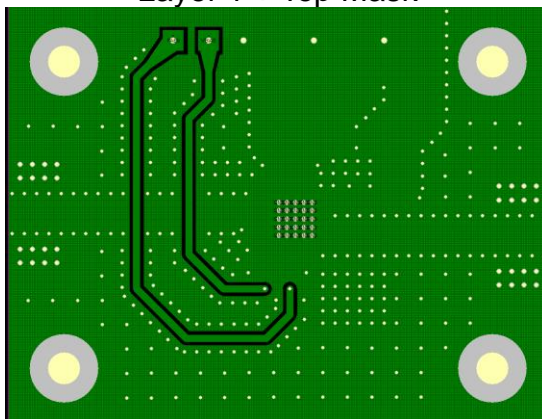



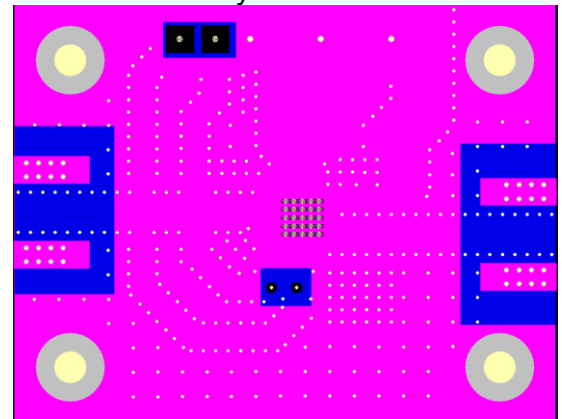





Layer 3

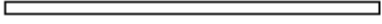

Layer 4 + Bottom Mask

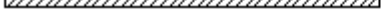
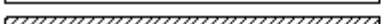
Layer Detail Physical Characteristics

50 Ohm	Cross Section	Name	Thickness(mm)	Materials
$W=0.500\text{mm}$ 		TMask	0.010	Solder Resist
		L1	0.035	Cu, 1oz.
		Dielectric	0.250	R04350
		L2	0.035	Cu, 1oz.
		Dielectric	0.350	FR4
		L3	0.035	Cu, 1oz.
		Dielectric	0.250	FR4
		L4	0.035	Cu, 1oz.
		BMask	0.010	Solder Resist

Application Circuit Notes

- Center Ground.** It is extremely important to sufficiently ground the bottom ground pad of the device for both thermal and stability reasons. Multiple small vias are acceptable and work well under the device if solder migration is an issue.
- GND (pins 1, 3, 4, 7, 8, 10, 11, 13, and 15).** Attach all ground pins to the RF ground plane with the largest diameter and lowest inductance via that the layout allows. Multiple small vias are acceptable and will work well under the device if solder migration is an issue.
- VCBIAS (pin 5).** The bias supply voltage for each stage, nominally set to +5 V.
- RFOUT (pin 9).** Amplifier RF output pin ($Z_0 = 50 \text{ Ohm}$). The module includes an internal DC blocking capacitor. All impedance matching is provided internal to the module.
- VCC1, VCC2, and VCC3 (pin 16, 15, and 12, respectively).** Supply voltage for each stage collector bias is nominally set to 5 V. The evaluation board has inductors L1 and L2. These are place holders, and should be populated with 0 Ohm resistors. Bypass and decoupling capacitors C6 through C12 should be placed in the approximate location shown on the evaluation board assembly drawing, although exact placement is not critical.
- RFIN (pin 2).** Amplifier RF input pin ($Z_0 = 50 \text{ ohm}$). All impedance matching is provided internal to the module.

Typical Part Marking

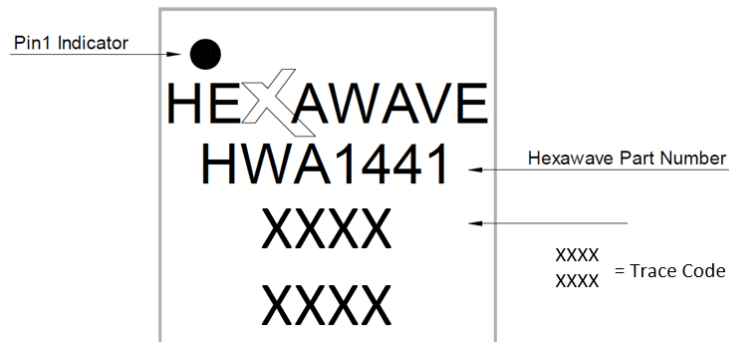

PCB Layout Footprint Patterns

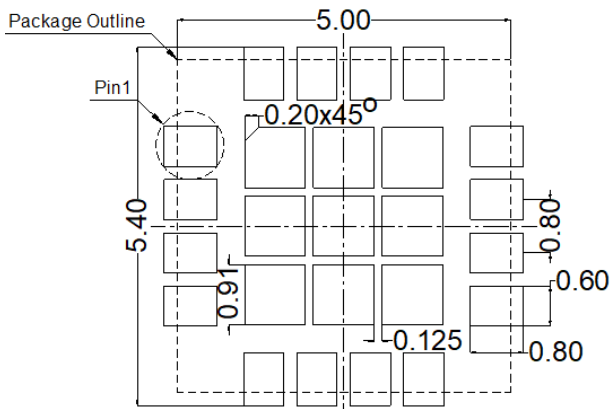

Stencil Aperture Top View

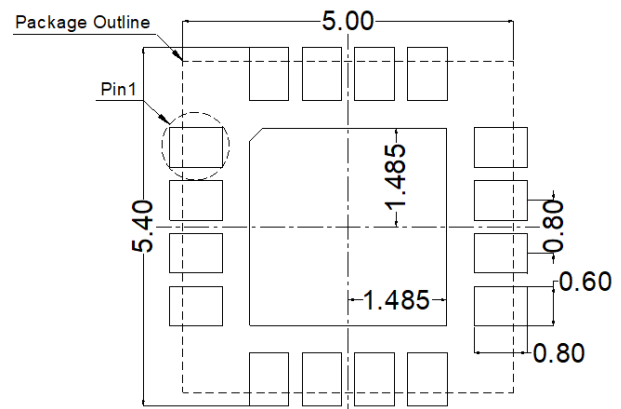

Solder Mask Opening Top View

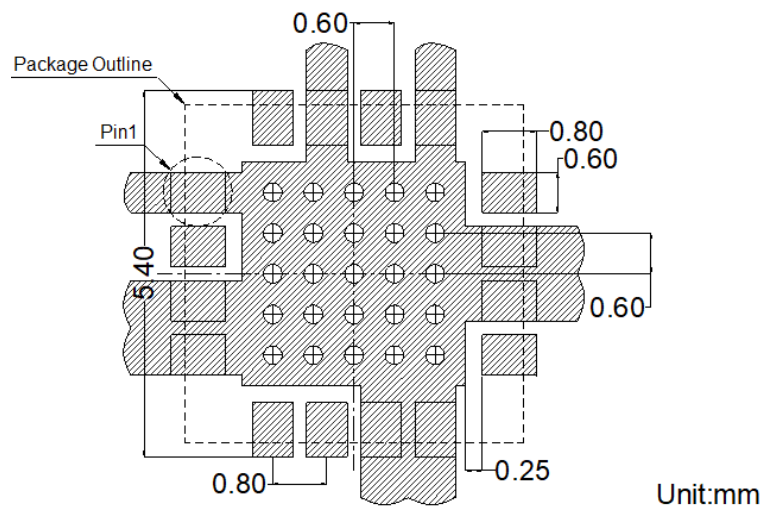

Metallization Top View

Package Dimensions

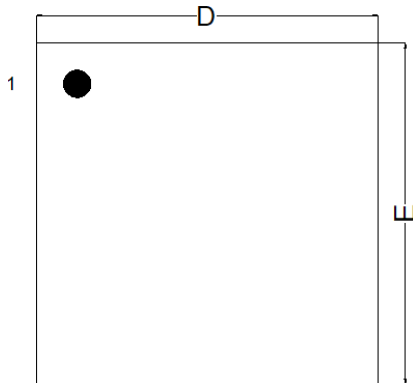

Top View



Side View

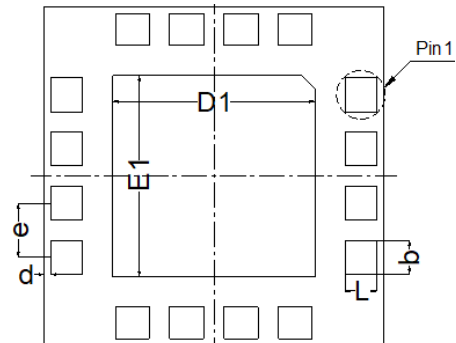

Bottom View

Symbol	Min	Max	Unit
A	1.00	1.14	mm
b	0.45	0.55	
D	4.90	5.10	
D1	2.92	3.02	
d	0.00	0.20	
E	4.90	5.10	
E1	2.92	3.02	
e	0.80 BSC		
L	0.42	0.52	

■ HWA1441 Tape and Reel Dimensions

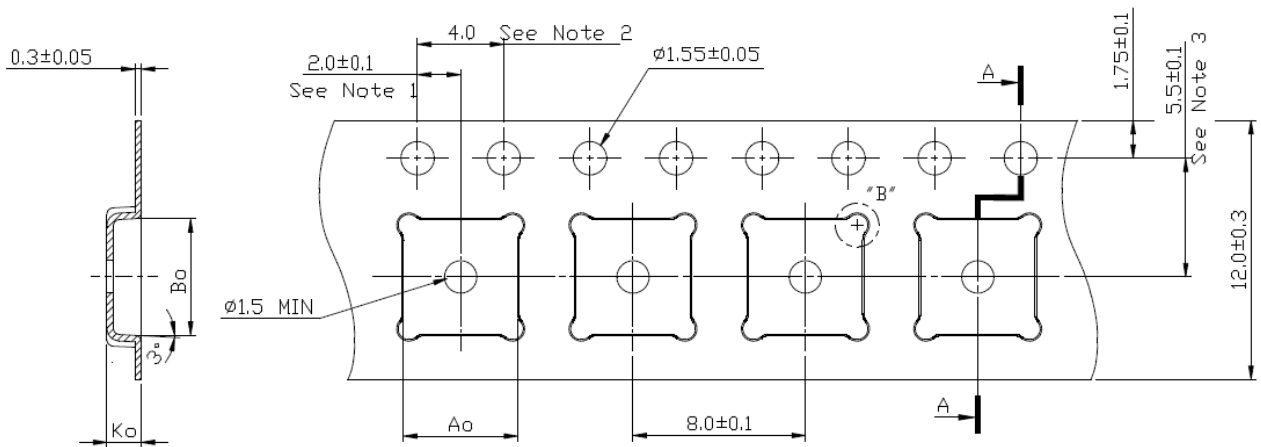

Section A-A

$A_o = 5.3 \pm 0.1 \text{mm}$
 $B_o = 5.3 \pm 0.1 \text{mm}$
 $K_o = 1.3 \pm 0.1 \text{mm}$

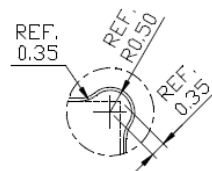

"B" Detail
S=2/1

Notes:

1. Measured from centreline of sprocket hole to centreline of pocket.
2. Cumulative tolerance of 10 sprocket holes is ± 0.20 .
3. Measured from centreline of sprocket hole to centreline of pocket.
4. Other material available.

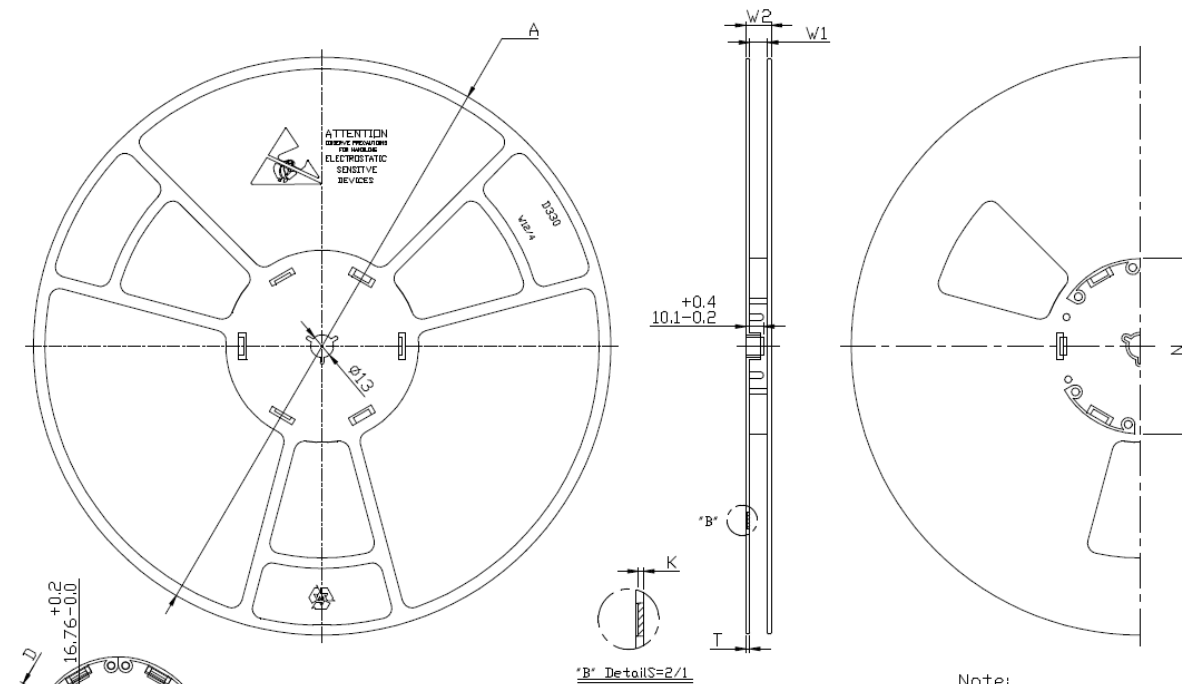

Note:
1. 材質：PS 抗靜電值 $1 \times 10^5 - 1 \times 10^{11}$

TYPE	A	N	C	D	W1	W2	T	K
8MM	$\phi 330^{+2.0}_{-2.0}$	$\phi 100^{+2.0}_{-2.0}$	$\phi 13.1^{+0.2}_{-0.2}$	$5.6^{+0.5}_{-0.5}$	$8.4^{+2.0}_{-0.0}$	$12.6^{+2.0}_{-0.0}$	2.1 ± 0.15	$1.4^{+0.15}_{-0.1}$
12MM	$\phi 330^{+2.0}_{-2.0}$	$\phi 100^{+2.0}_{-2.0}$	$\phi 13.1^{+0.2}_{-0.2}$	$5.6^{+0.5}_{-0.5}$	$12.4^{+2.0}_{-0.0}$	$12.6^{+2.0}_{-0.0}$	2.1 ± 0.15	$1.4^{+0.15}_{-0.1}$
16MM	$\phi 330^{+2.0}_{-2.0}$	$\phi 100^{+2.0}_{-2.0}$	$\phi 13.1^{+0.2}_{-0.2}$	$5.6^{+0.5}_{-0.5}$	$16.4^{+2.0}_{-0.0}$	$20.6^{+2.0}_{-0.0}$	2.1 ± 0.15	$1.4^{+0.15}_{-0.1}$
24MM	$\phi 330^{+2.0}_{-2.0}$	$\phi 100^{+2.0}_{-2.0}$	$\phi 13.1^{+0.2}_{-0.2}$	$5.6^{+0.5}_{-0.5}$	$24.4^{+2.0}_{-0.0}$	$20.6^{+2.0}_{-0.0}$	2.1 ± 0.15	$1.4^{+0.15}_{-0.1}$

■ Ordering Information

Part Number	Product Description	Evaluation Board Part Number
HWA1441	4400 to 5000 MHz Wide Instantaneous High-Efficiency PA	HWA1441-EVB